

Operation and Installation Manual

MSF90(Freezer)

and

MSL110(Refrigerator)

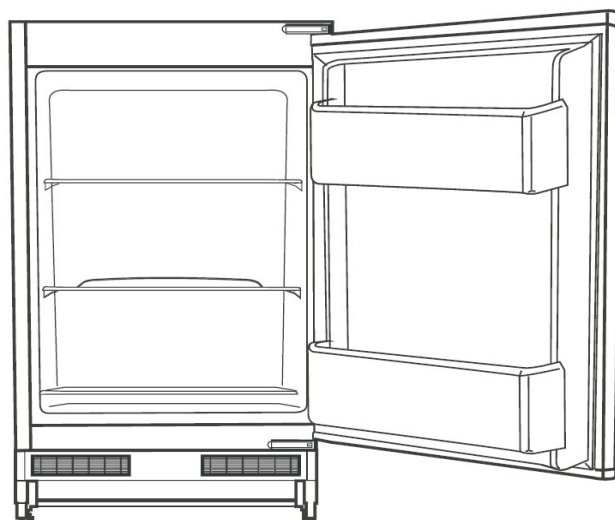
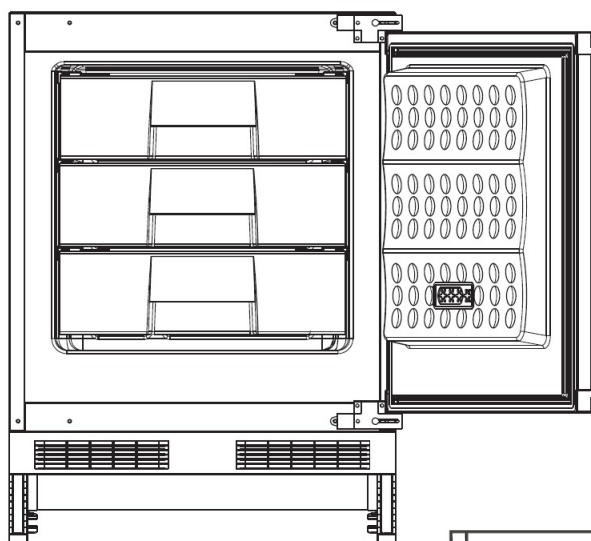

This appliance is intended to be used in household and similar applications including use in commercial settings. Such as staff kitchen areas in shops, offices and other working environments; by clients in hotels, motels and other residential type environments, such as bed and breakfasts, catering and similar non-retail applications.

Congratulations on the purchase of your new Schmick integrated fridge/freezer.

Before using your new appliance, please read this manual thoroughly to ensure that you know how to operate and install your new appliance safely and efficiently.

Warnings and general safety Instructions in this manual do not cover all possible conditions and situations that may occur. It is your responsibility to use common sense, caution, and care when installing, maintaining, and operating your appliance.

Because these following operating instructions cover various models, the features of your appliance may differ slightly from those described in this manual, and as such not all warnings in this manual will be applicable to your appliance.

WARRANTY – This unit comes with Australia wide 24 Month comprehensive warranty.

If you have any queries, please contact Bar Fridges Australia's on **1300 376 849** or email **vicservice@bar-fridges-australia.com.au** with your Fridge Model details, your Serial Number, and Invoice Number ready for all warranty queries.

Or complete the online form, found at the link below:

<https://www.bar-fridges-australia.com.au/making-a-warranty-claim.html>

Important Recycling Information

Up to end December 2025 Bar Fridges Australia now has deleted over 75% of EPS (Expanded Poly Styrene) and replaced with recyclable cardboard. Please note:

- The outer carton can be recycled in your local kerbside recycling bin.
- The plastic bag, the strap/s and foam padding are rubbish.

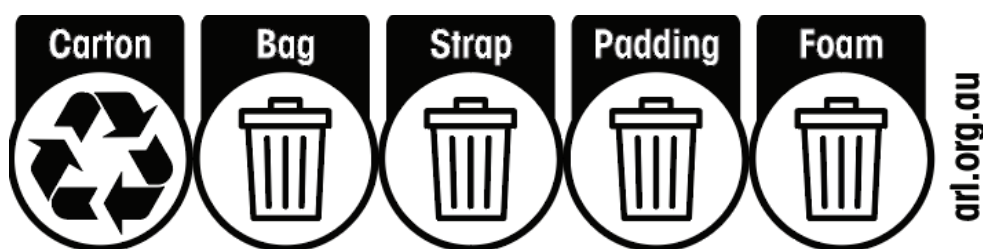

GENERAL SAFETY INSTRUCTIONS

READ CAREFULLY AND KEEP FOR FUTURE REFERENCE

Read this manual thoroughly before first use, even if you are familiar with this type of product. The safety precautions enclosed herein reduce the risk of fire, electric shock and injury when correctly adhered to. Keep this manual in a safe place for future reference. If applicable, pass these instructions on to the next owner of the appliance.



Pay particular attention to messages that follow this safety alert symbol or the words **DANGER**, **WARNING** or **CAUTION**. These words are used to alert you to a potential hazard that can seriously injure you and others. The instructions will tell you how to reduce the chance of injury and let you know what can happen if the instructions are not followed.



This symbol alerts you to take care as the appliance contains flammable materials: isobutane as refrigerant and cyclopentane as insulation blowing gas. While isobutane (R600a) is a gas with a high level of environmental compatibility, it is nevertheless flammable. Do not expose the appliance to high heat, sparks and open flames. During transport and installation, ensure that none of the components of the refrigerant circuit become damaged.

REFRIGERANT MATTERS

WARNING! Do not damage the refrigerant circuit!

Never use an appliance with a damaged refrigerant circuit!

If the refrigerant circuit becomes damaged, avoid proximity to open fires and all types of heat and ignition sources. Thoroughly ventilate the room in which the appliance is located. The room for installing the appliance must be at least 1m³ per 8g of refrigerant. The amount and type of refrigerant in the appliance can be found in the Technical Specifications on the 'Basic Instructions Page' and on the appliance rating plate.

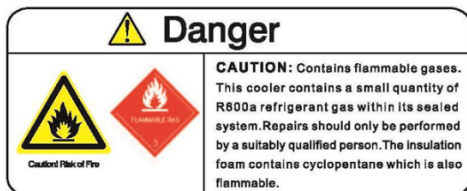

It is hazardous for anyone other than an authorised service person to service this appliance. In Queensland, the authorised service person **MUST** hold a Gas Work Authorisation for hydrocarbon refrigerants to carry out servicing or repairs which involve the removal of covers and the opening of refrigeration piping system.

RESPONSIBLE DISPOSAL

At the end of its working life, do not throw this appliance out with your household rubbish. Electrical and electronic products contain substances that can have a detrimental effect on the environment and human health if disposed of inappropriately. Observe any local regulations regarding the disposal of electrical consumer goods and dispose of it appropriately for recycling and recovery of the refrigerant and blowing agent. Contact your municipal authorities for advice on recycling facilities in your area.

WARNING! This refrigeration appliance contains flammable refrigerants and insulation blowing gases, which must be removed before disposal. Contact your municipal authorities for any codes or regulations concerning the disposal of such materials.

DANGER! Risk of child entrapment: When discarding this or another refrigerator, make sure to take off the door and leave the shelves/racks/drawers in place so that children cannot easily climb in and get trapped inside.

ELECTRICAL SAFETY

VOLTAGE

Plug the appliance in a 220-240V, 50Hz, properly earthed power outlet, which must be in good working order. Make sure your outlet voltage and circuit frequency correspond to the voltage stated on the appliance rating label

FLUCTUATIONS

If voltage fluctuates in your area, especially Perth and WA which is more common, you are best to invest in a voltage regulator, this can be purchased on our website, model AVS-1000.

POWER CONNECTION

Do not use an adaptor; do not use an extension cord. Plug the power plug directly into a separate power point that cannot easily be turned off accidentally, and that is easily accessible so you can switch it off when required.

POWER CORD

Do not kink or damage the power supply cord. Do not leave it exposed or dangling. Secure it behind the appliance so no one steps on or places anything on the power supply cord or against it. A squashed or damaged power plug may overheat and cause a fire.

DAMAGED CORD

Do not use a cord that shows cracks or abrasion damage along its length or at either end. Any damage to the cord may cause a short circuit, fire and/or electric shock. If the power cord is damaged, it must be replaced by the manufacturer or its service agent. To arrange a replacement, please contact the service department on **1300 376 849** or email **vicservice@bar-fridges-australia.com.au**

DISCONNECTION

Never unplug the unit by pulling the cord. Always grip the plug firmly and pull straight out from the power point.

ELECTRICAL WORK

If the installation of this appliance requires any electrical work (ie: if a new power point is required), make sure it is carried out by a qualified electrician.

USAGE CONDITIONS AND RESTRICTIONS

INDOOR DOMESTIC AND/OR COMMERCIAL USE

This appliance is intended for indoor domestic use or industrial / commercial only.

INTENDED PURPOSE

Do not use this appliance for anything other than its intended purpose, and only use it as described in this manual.

Do not attempt to alter or modify this appliance in any way.

USAGE RESTRICTIONS

This appliance is not intended for use by persons (including children) with reduced physical, sensory or mental capabilities, or lack of experience and knowledge, unless they have been given supervision or instruction concerning the use of the appliance by a person responsible for their safety.

WARNING! Do not use any electrical appliances (such as ice cream makers) inside refrigeration appliances, unless they are approved for this purpose, by the manufacturer.

USAGE CONDITIONS AND RESTRICTIONS (Con't)

CHILDREN

Supervise children to ensure they do not play with the appliance.

Close supervision is necessary when any appliance is used by or near children.

Never allow children to operate, play with or crawl inside the appliance.

AVOID CONTAMINATION OF FOOD

- To avoid contamination of food, please follow these instructions:
- Opening the door for long periods can cause a significant increase of the temperature in the compartments of the appliance.
- Regularly clean surfaces that can come in contact with food and accessible drainage systems.
- Store raw meat and fish in suitable containers in the refrigerator, so that it is not in contact with or drip onto other food.

NO USE FOR LONG PERIODS

If the refrigerating appliance is left empty for long periods, switch off, defrost, clean, dry, and leave the door open to prevent mould developing within the appliance

RESPONSIBILITY OF INSTALLATION & REMOVAL

These units require special installation - Bar Fridges Australia accepts no responsibility or costs in regards to the installation and/or removal of these units from required cabinetry, under ANY circumstances - including for any warranty repairs required.

CLEANING AND MAINTENANCE

WARNING!

Do not use sharp objects or metal instruments to remove frost or clean the appliance.
Do not use mechanical devices or other means to accelerate the defrosting process.
Do not use hairdryers or any electrical heaters to accelerate the defrosting process.
Do not use high pressure water to clean the appliance.
Use a plastic scraper, if absolutely necessary.

DISCONNECT

Unplug the appliance before cleaning or servicing. Failure to do so can result in electric shock, injury or death. Do not connect or disconnect the plug when your hands are wet.

FLAMES

Do not let open flames or ignition sources enter the appliance.

FLAMMABLE/EXPLOSIVE SUBSTANCES

Never clean this appliance with flammable fluids. Do not store or use volatile, flammable or explosive substances such as aerosol cans with a flammable propellant in or close to this or any other appliance. The fumes can create a fire hazard or explosion.

SOLVENTS

Clean the inside cabinet of cooler with a clean damp cloth, with neutral soap/detergent.
Avoid damage by never using abrasive or flammable cleaning products.
Do not use solvent based cleaning agents or abrasives on the interior as these may damage or discolor the surfaces of the appliances.

DOOR SEAL

Use eucalyptus oil twice a year with clean cloth to wipe and clean the 'door seal'.

STAINLESS STEEL

If you have purchased a stainless steel model, please see stainless steel care guide supplied with purchase.

CONDENSOR

Clean the condenser every 1-2 years with a vacuum cleaner and/or brush to eliminate any dust accumulating. The condenser is located at rear/bottom section of unit so it may require a technician to assist. In most cases in normal installations the build up of dust and particles will be very minimal so it may not be as important to do this at all.

SERVICE AND REPAIRS

Do not attempt to repair, modify or replace any part of the appliance unless specifically recommended in this manual. Refer all other servicing to a qualified technician, or contact the sales support line for advice on examination or repair of the appliance on **1300 376 849**, or you can also email us **vicservice@bar-fridges-australia.com.au**

ITEMS STORED INSIDE THE CABINET

- It is 100% not recommended to store blood, biological or special pharmaceuticals in the fridge.
- Keep items/drinks at least 1cm away from walls to allow better air flow
- Do not put bottled or canned drinks into the FREEZER compartment
- **Warranty does not cover 'contents' in any circumstance**

INSTALLATION BASICS

HEAVY

This appliance is heavy, take care when moving it. To avoid back or other injury, consider a two person lift or mechanical aid when installing it. Failure to do so can result in back or other injury.

BUILT-IN DESIGN

This appliance is designed to be 'built into' cabinetry. Do not operate this appliance without it being secured correctly to cabinetry.

NOTE: Front venting bottom grill must be kept clear at all time. Cabinet doors mounted to the fridge must allow adequate air flow to both front grills.

KEEP IT UPRIGHT

Do not tilt the fridge more than 45° from upright when moving it.

HANDLE WITH CARE

Do not apply force to any part such as the condenser or door
Do not carry the fridge, by carrying the door.

VENTILATION

Ensure proper ventilation by keeping any ventilation openings, in the appliance enclosure or in the built-in structure, free and clear of obstructions.

Ensure adequate air circulation around the appliance to prevent overheating.

POSITIONING

WARNING! When positioning the appliance, ensure the supply cord is not trapped or damaged.

WARNING! Do not locate multiple portable socket outlets or portable power supplies at the rear of the appliance.

LEVEL

Install the appliance level in order to ensure proper operation. If necessary, adjust the levelling legs at the bottom of the unit.

LOCATION

Install the appliance in an area that meets the following requirements:

- The ambient temperatures must correspond to the climate class (T) indicated on the rating plate of the appliance: (ie: (T) Rated is 16°C to 43°C)
- The floor must be sturdy, level and strong enough to support the unit when fully loaded.
- Avoid area's where the appliance would be exposed to direct sunlight, and/or sources of heat, (stove, heater, radiator, etc.),
- Avoid area's where the appliance would be exposed to extreme cold ambient temperatures or excessive moisture and high humidity (such as outdoors or exposed to wind, rain water spray or drips).
- Avoid positioning anywhere where water can penetrate 'under' or on 'top' of the cooler. It could cause damage to the internal workings and is potentially dangerous.
- Once into position: Allow at least 30minutes before turning the appliance "ON".

SUNLIGHT

The fridge must not be exposed to direct sunlight.

INSTALLATION TIP: Installing it in the coolest area of the room will the room will save energy consumption and running costs.

The importer is not responsible for damages or accidents arising from the misuse or disregard of electrical laws relevant to the country where this product is used.

SETTING UP YOUR NEW MSF90 / MSL110 – (BASICS)

REMOVE PACKAGING

Unbox your unit, and remove all packaging materials, including the foam base, and any adhesive films and/or tapes from the fridge/freezer.

Remove all protective films, to ensure the thermal dissipation from the appliance.

CHECK YOUR PARTS

Check the parts and accessories inside the packaging, against the components list (see below).

If you are missing any parts, please call **1300 376 849**, or you can also email us **vicSERVICE@bar-fridges-australia.com.au**

INSTALL INTO LOCATION

Install your new fridge/freezer into your desired location. Further detailed instructions can be found within this manual.

CLEAN BEFORE USE

Before use, please clean the inside cabinet of cooler with a clean damp cloth with a neutral soap/detergent.

DEFAULT TEMPERATURE SETTING

MSF90 - Freezer

Once connected to a power supply, the freezer will take some time to reach its default preset temperature of -18°C.

MSL110 - Fridge

Once connected to a power supply, the fridge will take some time to reach its default preset temperature of 5°C.

Once the appliance has reached its set temperature (around 2-3hrs after powered up), you can then place food inside.

SHELF RATING

Each MSF90 freezer shelf is rated for UPTO 24kg of product. Do not exceed this.

Avoid overcrowding the shelves, as this will reduce air flow, and therefore efficiency.

Allow the MSF90 - freezer to run for around 24hours, once filled, to reach a stable temperature. After this period, the temperature can then be changed.







TIP: After changing the temperature setting, it will take some time before the fridge or freezer reaches a balance across the whole compartment. How long this takes will depend on the ambient temperature, the food stored inside, and how often the door is opened.

FREEZER CAPACITY RATING

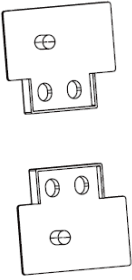
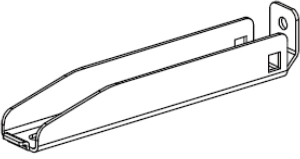
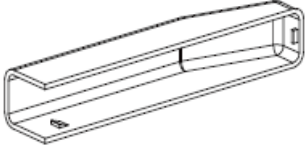
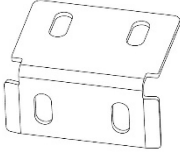
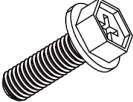
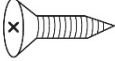
The MSF90 model has a freezer capacity rating of 4 stars, as per below

Rating	1 Star	2 Star	3 Star	4 Star
Freezer Capacity	-6°C	-12°C	-18°C	-24°C

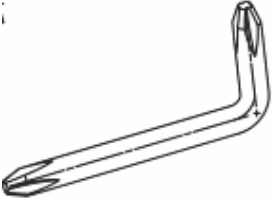
PARTS AND COMPONENTS LIST - MSF90 / MSL110

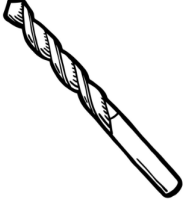
<p>HINGE PLATES</p>  <p>QTY: 2 (1 EA)</p>	<p>TOP FIXING BRACKET</p>  <p>QTY: 1</p>	<p>FIXING BRACKET COVER</p>  <p>QTY: 1</p>
<p>BOTTOM FIXING BRACKET</p>  <p>QTY: 2</p>	<p>HEX FLANGE SCREW</p>  <p>QTY: 2</p>	<p>COUNTERSUNK SCREW</p> <p>A</p>  <p>QTY: 18</p>
<p>FLATHEAD SCREW</p> <p>B</p>  <p>QTY: 4</p>	<p>DOME HEAD SCREW</p> <p>C</p>  <p>NOTES: ALREADY INSTALLED TOP AND BOTTOM OF FRIDGE DOOR</p> <p>QTY: 4</p>	<p>CAP SCREW WITH WASHER</p> <p>D</p>  <p>NOTES: 4 X ALREADY INSTALLED ON FRIDGE DOOR</p> <p>QTY: 6</p>
<p>L-TYPE SCREW DRIVER</p>  <p>QTY: 1</p>	<p>DRILL/DRIVER</p>  <p>REQUIRED - NOT SUPPLIED</p>	<p>2MM DRILL BIT</p>  <p>NOT SUPPLIED (PRE-DRILLING RECOMMENDED FOR CABINetry)</p>

REVERSING THE DOOR HINGE

(RIGHT HINGE TO LEFT HINGE)

Directions and diagrams are based on a right hand hinged door, being swapped to a left hand hinged unit. If swapping from left to right, simply mirror the instructions)

If you require the door swing to be changed, you can easily do this at home with a screw driver.

Steps below may vary, depending on if fridge is straight out of the box or has already been installed. However, it is best to decide which side hinge is required, **before** installing into cabinetry.

- Switch off power at the wall socket, and pull out the plug.
- Remove all food, loose items and fittings inside the fridge, AND door shelves (if fitted).
- Unscrew all hinge bolts, top and bottom, and remove both the upper and bottom hinges from the fridge body AND fridge door.
- Remove the plastic hinge plate (if already assembled)
- Remove plastic grommets/covers on opposite side, where hinge is to be placed.
- Reposition and (loosely) refit the **upper** hinge, on the opposite **bottom** side.
- Reposition and (loosely) refit the **bottom** hinge, on the opposite **top** side.
- Refit the plastic hinge plates as required. (top to bottom, bottom to top).
- Locate and (loosely) refit fridge door to both hinges.
- Once in the correct position, tighten all bolts to secure.
- Refit the plastic grommets/covers on the opposite side, where the hinge's were.

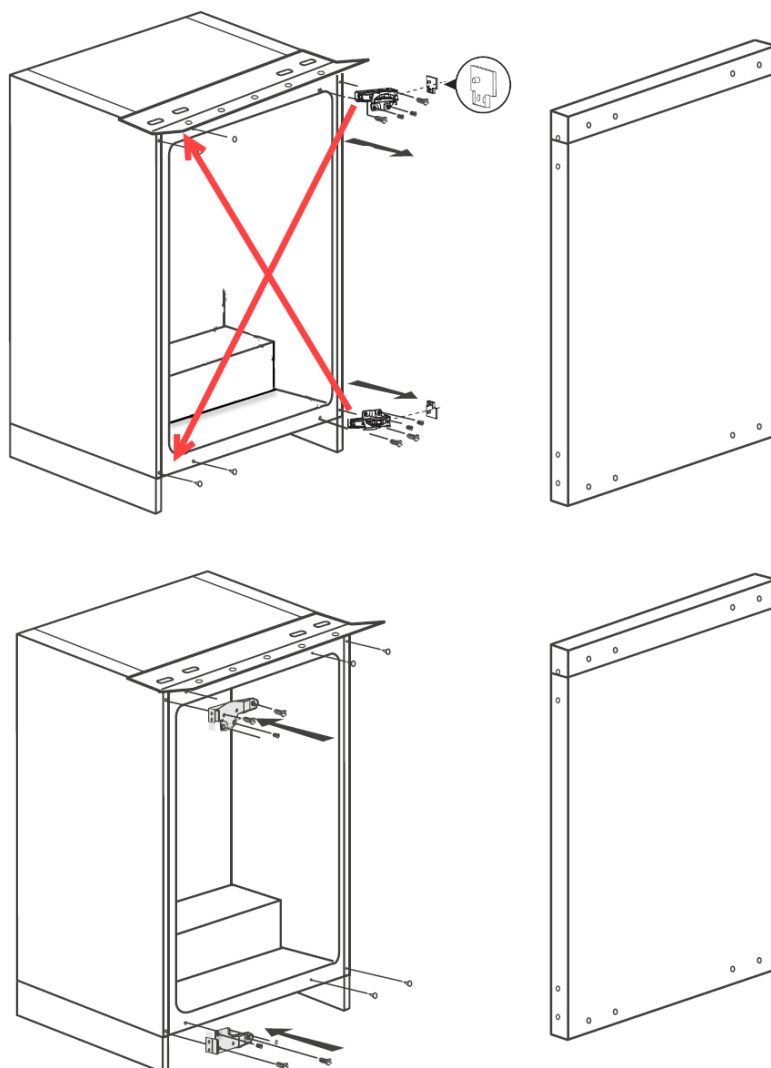

STEP-BY-STEP INSTALLATION - MSF90 / MSL110

Important information

- This appliance must be fixed into position in accordance with these instructions.
- Do not operate this appliance unless it is installed into cabinetry.
- The appliance must be installed on a smooth flat surface.
- There is four (4) front and rear feet that can be adjusted (clockwise and anti-clockwise) as required, to ensure the appliance is level and square inside the cabinetry.
- Correct adjustment of the feet avoids excessive noise and vibration, and correct alignment of the cabinetry doors.

FRIDGE/FREEZER MEASUREMENTS

Height range	820mm >870mm (adjustable to fit cabinetry)
Width	595mm
Depth	540mm

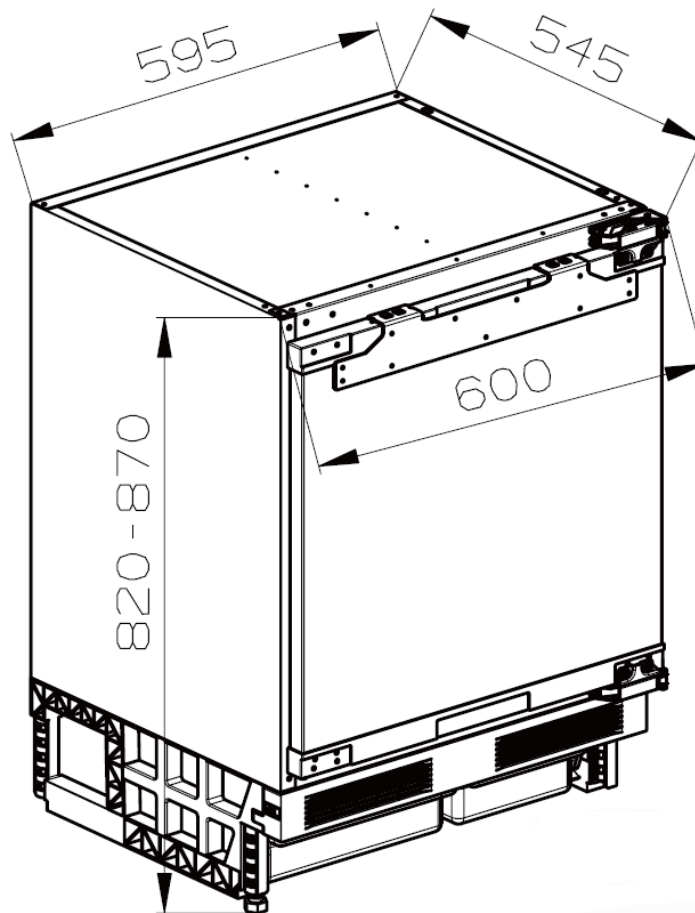

WARNING: This fridge/freezer vents through the front grills. Care must be taken to not block/obstruct these air channels.

Minimum distance between walls/cabinets and the appliance must be **at least** 10 mm

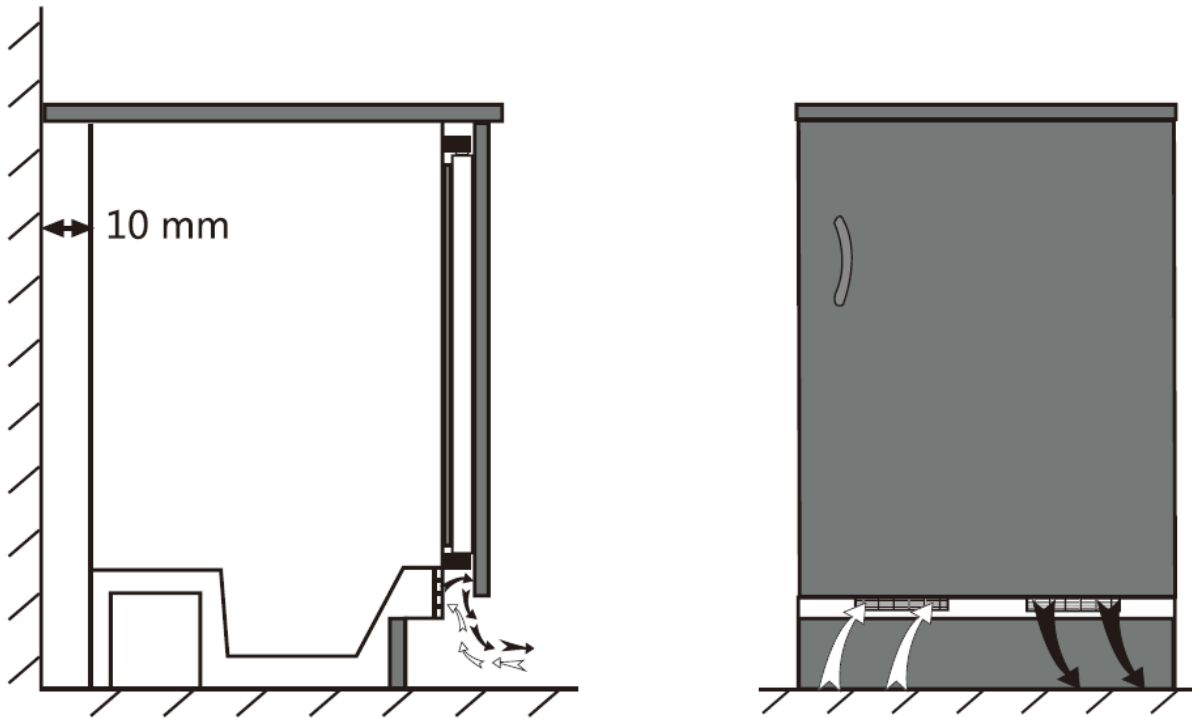

Allow for a minimum of 140cm² of air flow, calculate using Width x Height (20cmW x 5cmH = 100 cm². Most times the door is forward more than fridge, with skirt board behind, leaving a gap for venting that is effectively 'hidden'.

It is recommended to have ventilation into cabinets on 'either side' of the appliance, or allow 40mm clearance at back of cabinets at 'left and right' side of unit, if possible.

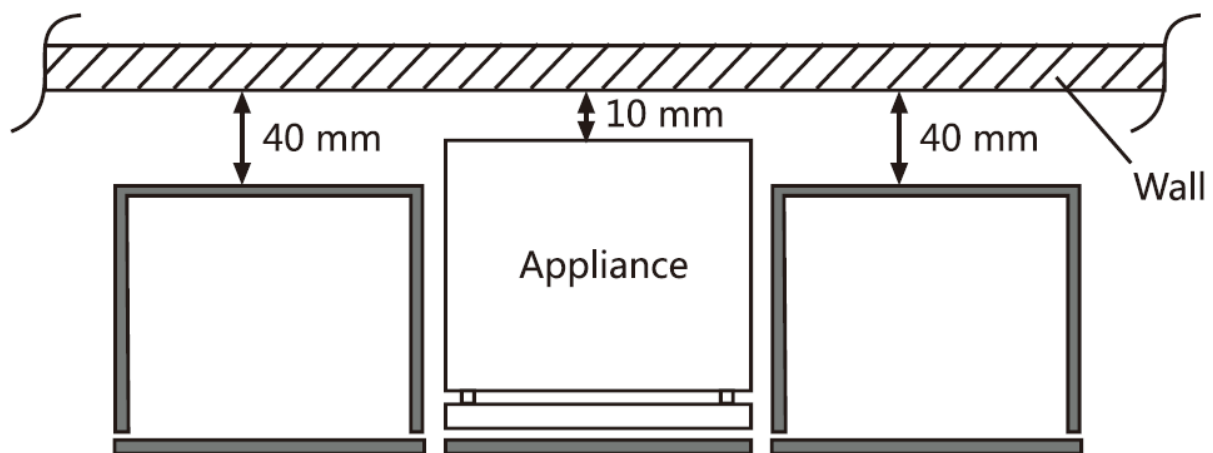

CABINET SIZE REQUIREMENTS (INTERNAL MEASUREMENTS)

Height	820mm >870mm (dependant on bench height)
Width	At least 600mm (+<10mm)
Depth	At least 550mm
C: Kickboard height	100>150mm (dependant on cabinetry design)
D: Cabinetry door height from floor	120>170mm< (so not to block air channels)

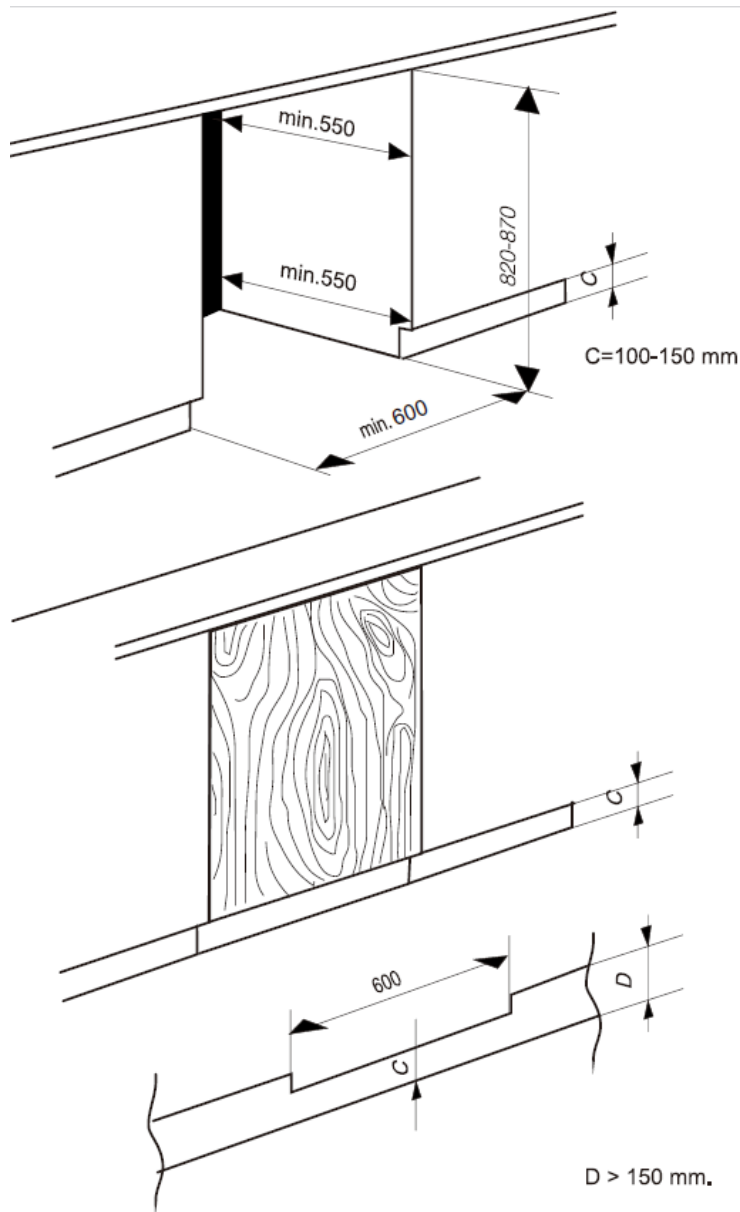

NOTE: Diagrams are true for right hand hinged units.
Mirror application, if appliance is left hand hinged)

NOTE FOR CABINET MAKERS: Depending on cabinetry layout, door width will depend if it will be either flush with end of vertical wall of cabinet body, OR half distance of cabinet wall thickness, if sharing cabinet carcass wall with another cabinet door. Ensure you allow for a standard 2-2.5mm gap between cabinetry panels/doors if sharing carcass wall.

INSTALLATION

Step 1 - Securing Top Fixing Bracket to the appliance.

- Secure the Top Fixing Bracket with the Hex Flanged screws, to the same side as the hinge.
- Fit plastic hinge plates (circled in diagram), into side of appliance hinge.

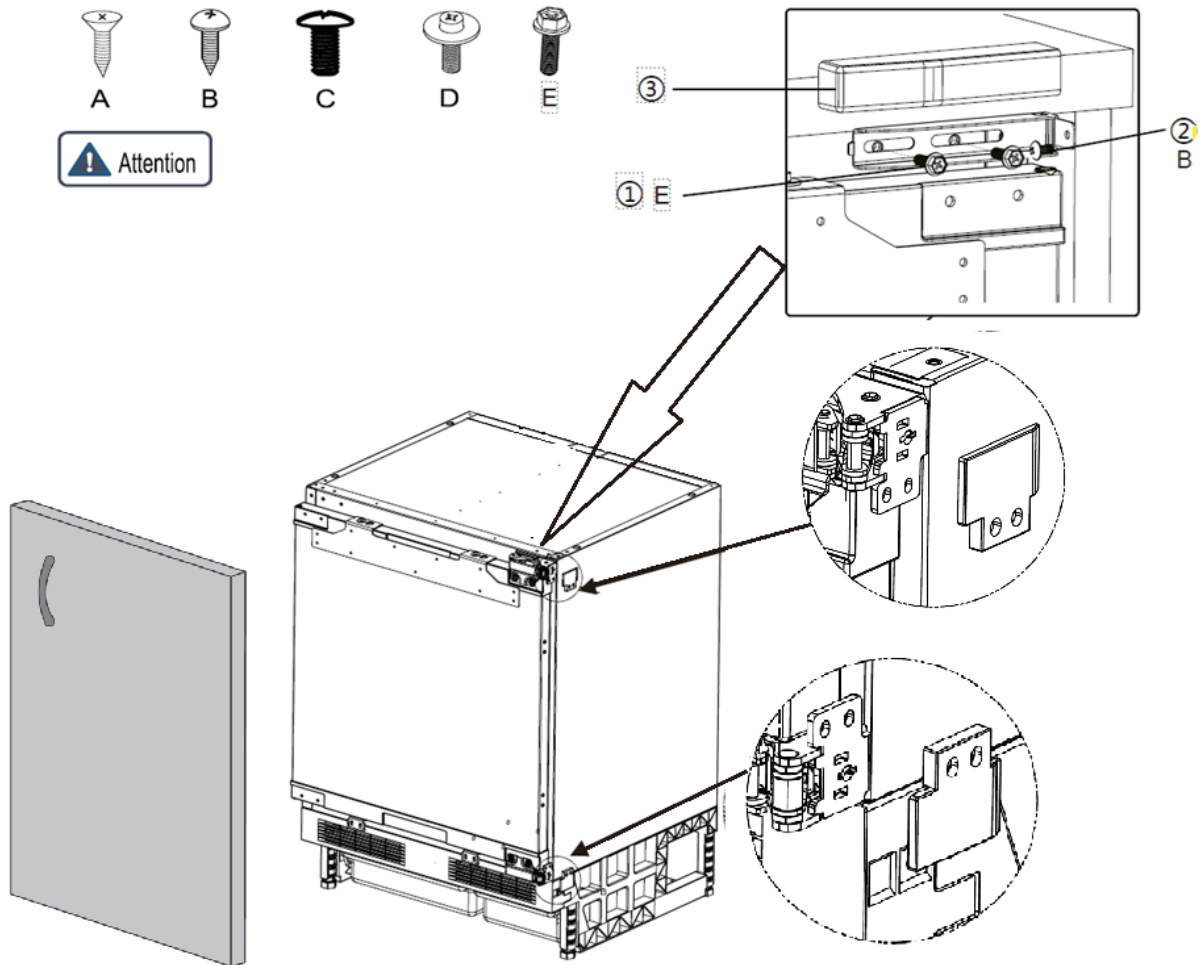

NOTE: Do not overtighten the screws when connecting to the top plastic parts.

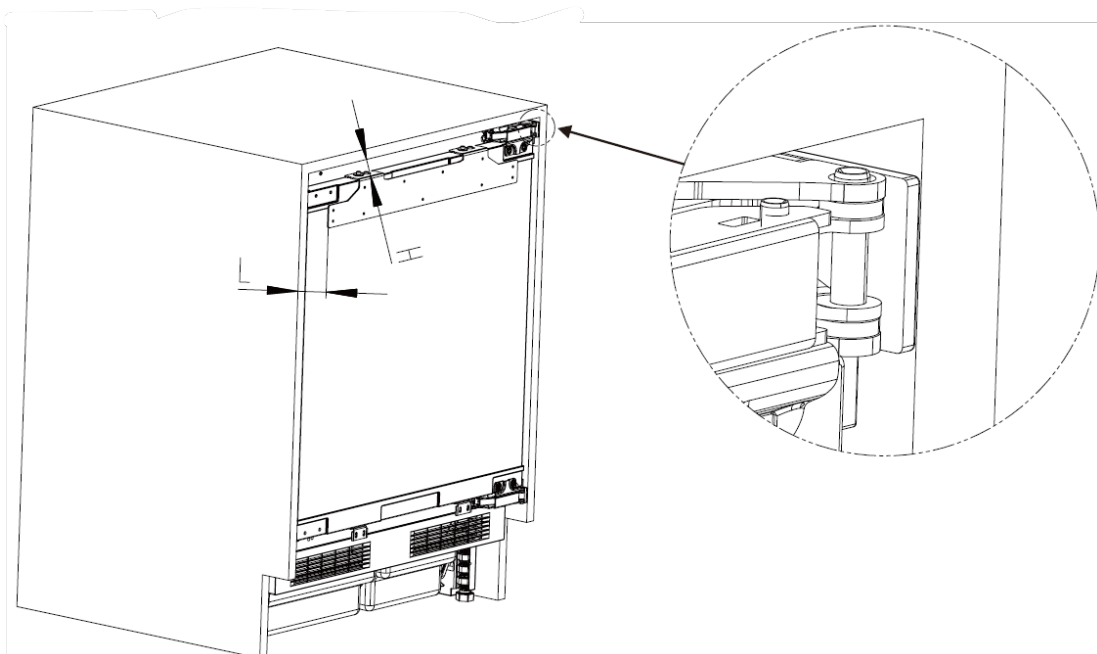

Step 2 – Securing the appliance to the cabinetry

- Pass the power cord through your access hole in the back of the cabinet OR, if power socket is sharing the cabinet niche plug the cord into the socket
- Move the fridge/freezer into cabinetry as desired.
WARNING! Be careful not to damage power cord, when positioning appliance into cabinet niche.
- Slide fridge to hinge side of cabinet, so front edge of top fixing bracket and hinge plates fit flush against edge of cabinet wall.
- Adjust all 4x feet so plastic top mount sits flush with top edge of cabinetry
- Do **NOT** fix to cabinet just yet.
- With fridge/freezer in place, and with door mounting plate still on fridge, measure distance from top edge of cabinet, to bottom of door mounting plate (H).
- Also measure from end of door mounting plate, to where cabinet door will sit (L)

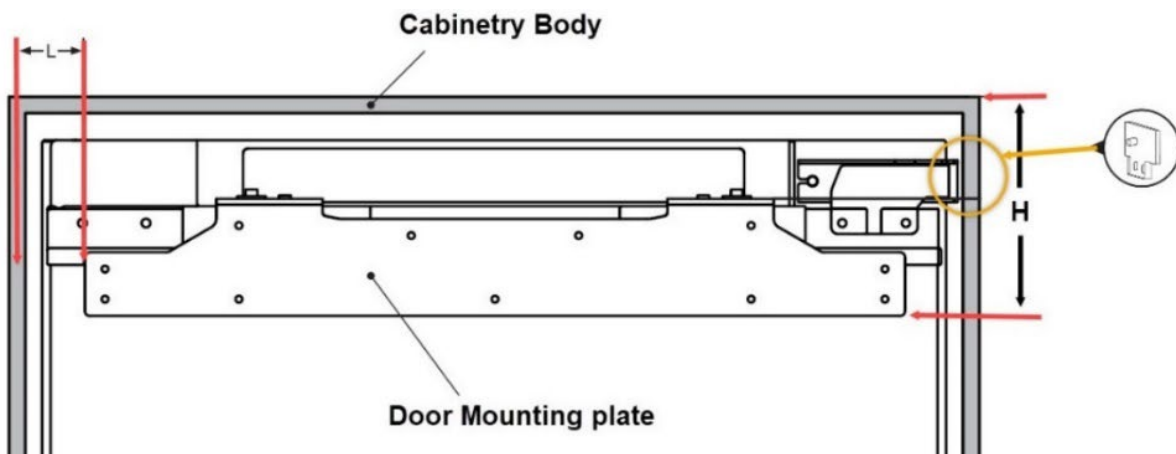

NOTE FOR CABINET MAKERS: Depending on cabinetry layout, L, will be either flush with end of vertical wall of cabinet body, OR half distance of cabinet wall thickness, if sharing cabinet carcass wall with another cabinet door. Ensure you allow for a standard 2-2.5mm gap between cabinetry panels/doors if sharing carcass wall.

Step 3 – Securing the cabinet door to the appliance (Top)

- Remove door mounting plate from fridge/freezer door by removing the 2x Cap Screw with washer (D).

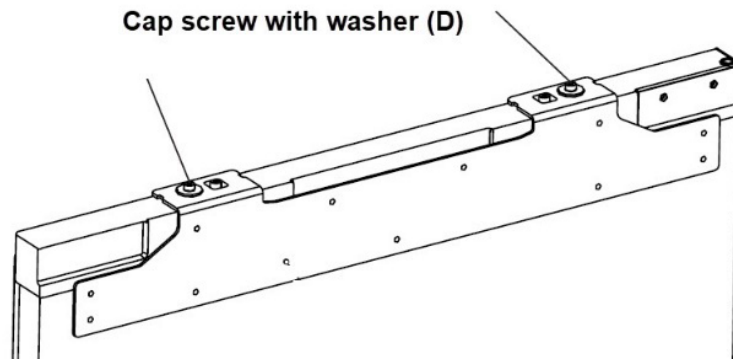

- Place door mounting plate, onto the REAR side of your cabinetry door, and measure and mark out, your measurements for (H) and (L) as per the diagram below.

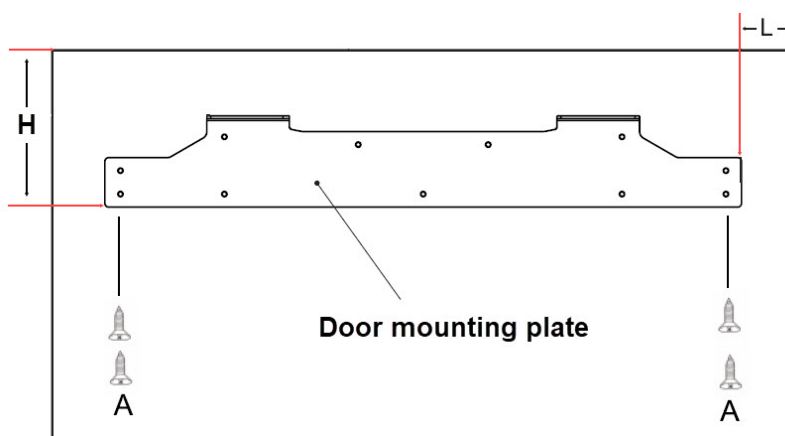

- Once marked accurately, fix the door mounting plate to cabinet door, with 4x Countersunk screws (A)
- Once mounting plate has been secured to cabinet door, the door can now be hung back onto the fridge door.
- Secure the door mounting plate to the fridge door with the 2 x cap screws, previously removed in this step. These can be adjusted slightly to suit cabinetry if required (see step 6)

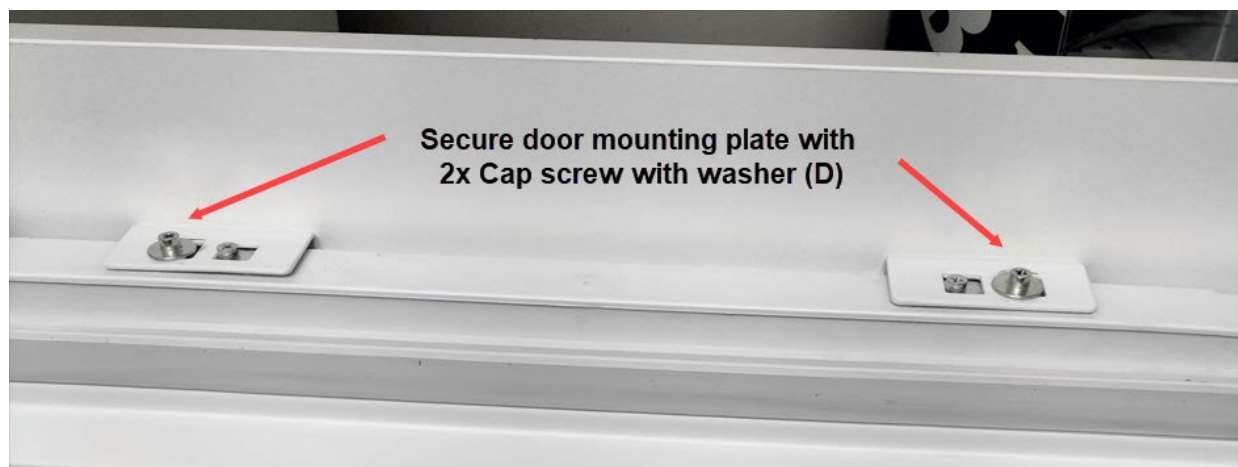

Step 4 – Securing the cabinet door to the appliance (bottom)

1. Remove the 4x Dome head screws from under the bottom edge of the fridge/freezer door
2. Fix the 2x Bottom fixing brackets to fridge door, with the 4x Dome head screws that you just removed.

NOTE: Do **NOT** fix the bottom fixing bracket to the cabinet door just yet.

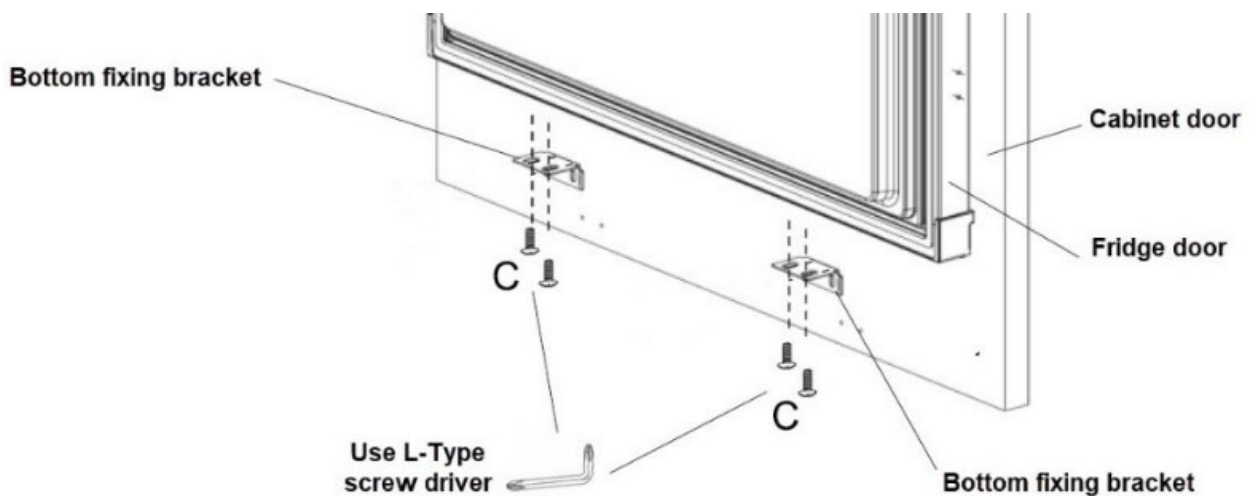

Step 5 – Securing the appliance to the cabinetry

- Align front edge of hinge plate, with front edge of cabinet vertical wall.
- Also align plastic top mount with front edge of cabinet top/bench
- Fix 2x Countersunk screws (A) into the side wall of the cabinetry, through the hinge plate brackets.
- Use a countersunk screw to secure the Top Fixing Bracket, to the side of the cabinet.
- Clip the Top Fixing Bracket cover over the top of the bracket.

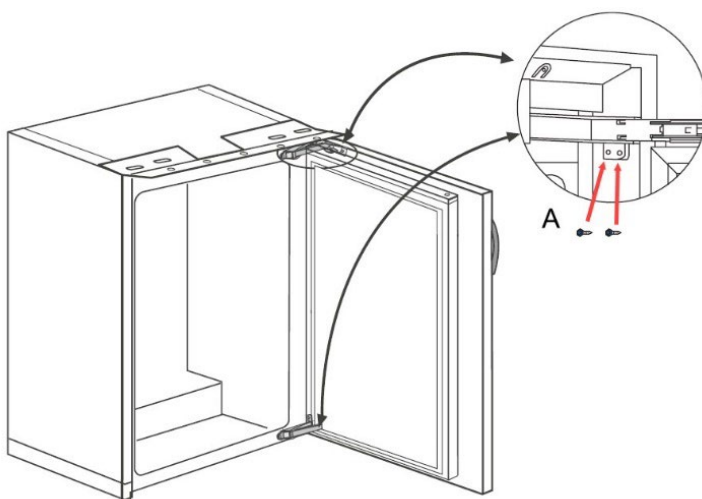

Step 6 – Adjusting cabinet door

The cabinet door can be adjusted a number of ways.

Top Adjustment

Firstly, Loosen both outer Cap screws (D1) on top of fridge door.

Up and Down adjustment

- The inner cap screws (D2) can now be adjusted upwards or downwards with a screw driver, as required.

Front and Back adjustment

- The door can also be adjusted backwards or forwards, by moving the cabinet door in or out, as required on top of the inner cap screws (D2).

Left or Right adjustment

- The door can also be adjusted left or right, by moving the top door mount, as required on top of the inner cap screws (D2).

Once the desired position is achieved, tighten both outer cap screws (D1) to secure.

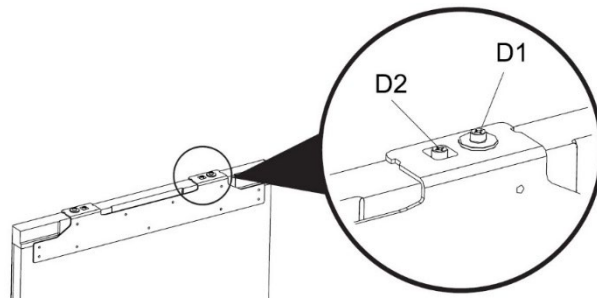

Bottom Adjustment

Firstly, only slightly loosen the 4x Dome cap screws (C) on the bottom of the fridge door.

Depth

- The door can also be adjusted backwards or forwards, by moving the cabinet door in or out as required (Z)

Once the desired position is achieved, tighten all 4x Dome cap screws (C) to fix into position.

The bottom fixing bracket, can now be secured with 4x Countersunk screws (A) to the cabinet door.

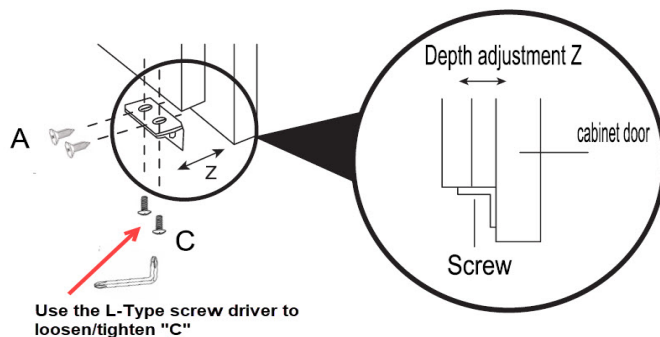

Step 7 – Insert sealing Strip

Once fridge and cabinet door have been adjusted accordingly, the sealing strip can be inserted between the fridge and cabinet body.

CONTROLLER

This appliance uses an electronic thermostat/controller, located in the lower kickplate.



	Min Set Temp	Max Set Temp	Recommended
Fridge (MSL110)	-2°C	8°C	2°C
Freezer (MSF90)	-16°C	-24°C	-18°C

OPERATING THE CONTROLLER

UNIT ON / OFF

Press and hold "Set" and the  buttons together, for 3 seconds and the unit will turn on or off



ADJUST THE TEMPERATURE

Press and hold the "Set" button for 3 seconds.

The display will then show "St"

To **raise** the set temperature, press the  button.

To **lower** the set temperature, press the  button.

Don't press a key for 30 seconds to exit.

The temperature set point will be automatically saved.



LIGHT ON/OFF

Press the  button to turn light on and off (only for models with lights)

ALARMS

Alarm Code	Cause
E1	Cabinet temperature probe fail
E2	Evaporator temperature probe fail
E3	Condensor sensor fail
cH	High condensor temperature alarm
rH	High cabinet temperature alarm
rL	Low cabinet temperature alarm

CONTROLLER SYMBOLS / BUTTONS

SYMBOL/BUTTON	DESCRIPTION
Set	Enter parameter setting mode Switch between menu and parameter
	Adjust up in menu and parameter settings Turn on/off the light (only for appliance with light)
	Adjust down in menu and parameter settings View the value read by the condensor probe Press and Hold for 10 seconds to restore parameters with one button
	View the value read by the evaporator probe Exit parameter setting mode Exit parameter restore mode Press and hold for 3 seconds to force switch between cooling, defrost/defrost delay and dripping

NOTE: It is not recommended to change parameters, other than desired set temperature.

TROUBLE SHOOTING / BASIC INFO

There are basic things you need to look and check before trying to initiate a technician call out for warranty circumstances.

KNOWLEDGE BASE

This link to our Knowledge Base may be able to assist you with troubleshooting.

<https://www.bar-fridges-australia.com.au/knowledgebase>

NOISE

If your unit has become noisy, please check the following;

- Can you ascertain exactly where the noise is coming from? It may be a loose screw or part of the fridge that is now vibrating and is easy to fix.
- Is the compressor / fridge level, a compressor not level will make a 'clunking' noise on start-up and shut down.
- Does the fan sound noisy? It may be as simple as needing slight adjustment or you may see ice build up near the fan inside.
- A slight sound may be heard when the liquid refrigerant circulates
- A slight sound may be heard when defrosted water drops into the drip tray.

NOTE: The compressor and fans will run for longer periods if excessive quantities of food / drink are stored or the ambient temperature is high.

NOT COOLING

All of a sudden unit has stopped cooling.

- Have you got the thermostat set correct? Or has it been altered or changed.
- Is your door sealing properly, check all the way around door seal to make sure it is seating correct on fridge body, small gaps won't affect cooling.
- Check inner and rear fans are going
 - If you can NOT see the individual blades stationary, the fans will be running
- Does the compressor run? Make sure compressor is running. If it is running and still not cooling and you have a warm fridge then there may be a gas problem and a technician will be needed.

COMPLIANCE

All units have been registered under section 43 of the Greenhouse Minimum Energy Standards ACT 2022, using AS/NZS62552 and AS/NZS4474 Testing Standard (GEMS).

This product has been fully tested and meets all requirements as set out by electrical and safety standards AS/NZS 60335.1 and AS/NZS 60335.2.24



The RCM Mark (Regulatory Compliance Mark) indicates that the product complies with the relevant guidelines of the ACMA as well as corresponding government requirements for the safety of electrical devices.



BAR FRIDGES
Cooling the Beers of a Nation Australia

www.bar-fridges-australia.com.au